



OMC-160 Wind speed & direction sensor

The popular and often used wind sensor OMC-160 is a combined wind speed and direction sensor, based on the cup and vane principle. Having chosen for the highest quality stainless steel materials and internal non-contact measuring devices, this sensor stands for a long life time, having the highest accuracies within both the low range as well as the high range wind speeds. This sensor is commonly used within the shipping and offshore industry but can also be found on many airfields, container terminals and harbours, along highways and on bridges.

Features:

- High accuracy sensor
- Approved by CAA
- Contact free sensing elements
- High reliability in every environment
- All exposed parts in Stainless steel
- Serial TTY output or NMEA0183 (standard)
- Cable length up to 1000 m (4 core)
- Heated option available
- NATO stock no: 6660-17-112-7536



OMC-160 installed on tanker



OMC-160 installed on mega yacht

GENERAL

The OMC-160 comprises a combined in-line wind speed and wind direction sensor. The system is robust, corrosion resistive and easy to install. The wind speed sensor is a rotary-cup type, made UV resistant high quality polycarbonate. Rotation of this cup-unit generates pulses in an optical encoder. The encoder is directly connected to the internal microprocessor. The wind direction sensor is a wind vane type, made from stainless steel. The wind vane drives a resolver, which is directly connected, to the internal microprocessor as well.

The microprocessor translates the sine and cosine output from the resolver and the pulses from the wind speed into a combined digital string. Standard the wind sensor is supplied with a TTY output but also an NMEA0183 might be selected. Output frequency may also be selected from 1, 2, 3, or 4 times per second.

The wind sensor comes with a vertical mounting bracket which includes a junction box and two u-bolds for mast mounting

Observator has an in-house wind tunnel facility but is also able to provide a third party, traceable wind tunnel test certificate. This can be ordered as type number OMC-154 and will be drawn up by the University of Brussels.

DATA SUMMARY

POWER REQUIREMENTS

8 TO 30 VDC 60 mA

OUTPUTS

Currentloop ASCII coded output 20 mA
NMEA-0183 version 2.30 (standard)

DIMENSIONS, AS PER SKETCH

Weight 6.5 kg

Mounting pole with two clamps for pole max. 65 mm dia

ENVIROMENTAL

Operating temperature -25 to 70°C

Moisture protection IP65

Humidity 10 to 100%

EMC EN 50081-1 class B, EN 50082-2

Conform RoHS directive 2002/95/EC en 2005/18/EC

ACCURACY

Wind speed: better than 2% FRO

Wind direction: better than 3 degrees

Speed range: 0,3...75 m/s

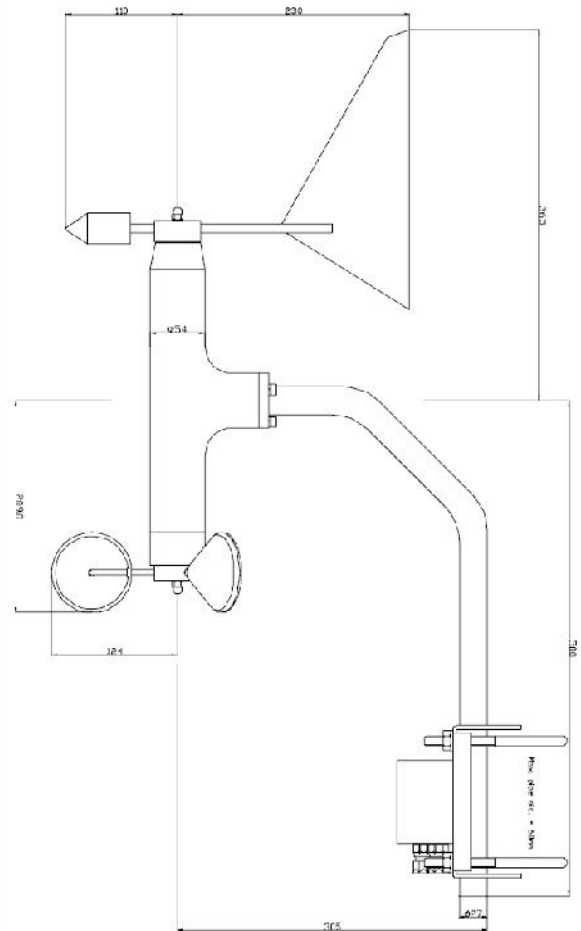

The Observator range is in continuous development and so specifications may be subject to change without prior notice

 **OBSERVATOR**
instruments

Rietdekkerstraat 6
2984 BM Ridderkerk

P.O. Box 60
2980 AB Ridderkerk
The Netherlands

Phone +31 (0)180 463 411
Telefax +31 (0)180 463 530
E-mail info@observator.com
www.observator.com