



OMC-150 /158 Intrinsically safe wind sensor

The OMC-150 is an Intrinsically Safe combined wind speed and direction sensor, based on the cup and vane principle. A complete wind set consists besides this sensor of an Eex junction box which is placed nearby the sensor OMC-156, and a Zener barrier interface box OMC-158. Using a sin/cos potentiometer wind direction is measured without a dead-band, while speed is measured using a proximally switch and a code cap. The unit is made from stainless steel and comes with a mounting arm which can be clamped to a mast using two U-Bolts.

Features:

- High accuracy sensor according W.M.O.
- Meets ATEX directive 94/4/EEG; EN 50014 EN 50020 and EN 13463-1
- Type approved EEx ia IIC T4
- Equipment category II 2 G
- Certificate number KEMA 03ATEX1146
- Permitted in Zone 1 and 2
- High reliability in every environment
- All exposed parts in stainless steel 316
- Plugged connection
- Most cost effective solution for wind measurement in hazardous areas



Oil rig



FPSO

GENERAL

The OMC-150 comprises a combined in-line wind speed and direction sensor. The system is robust, corrosion resistant and easy to install.

The wind speed sensor is a rotary-cup type unit, made in stainless steel; rotation of the cup-unit generates pulses with the aid of a proximity switch.

The wind direction sensor is a wind vane type unit made in stainless steel. The wind vane drives a sin/cosine potentiometer.

The mounting bracket can be clamp mounted on a vertical pipe with an external diameter between 35 and 62 mm using two U-bolt clamps. A watertight cable plug is mounted on the bracket.

Inside the safe zone the sensor is connected to the OMC-158 Zener Barrier Box.

This consists of an aluminum case containing the interface printed circuit board and three safety barriers.

The inputs to the Zener Barrier Box are the wind speed and direction signals originating from the OMC-150.

The output message of the Zener Barrier Box contains the wind speed and direction. This is the standard Obsermet current loop signal with ASCII information, provided at 300 baud.

Observator has an in-house wind tunnel facility but is also able to provide a third party, traceable wind tunnel test certificate. This can be ordered as type number OMC-154 and will be drawn up by the University of Brussels.

A complete system consist of,
OMC-150 Wind Sensor
OMC-158 Zener Barrier Box



Rietdekkerstraat 6
2984 BM Ridderkerk

P.O. Box 60
2980 AB Ridderkerk
The Netherlands

Phone +31 (0)180 463 411
Telefax +31 (0)180 463 530
E-mail info@observator.com
www.observator.com

DATA SUMMARY

POWER REQUIREMENTS

- 12..18 VDC, 100mA

SENSOR OUTPUT

- Potmeter for direction
- Pulse signal for speed

OMC-158 OUTPUT

- Currentloop ASCII coded output

DIMENSIONS, OMC-150 SEE SKETCH

- Weight 5 kg
- Mounting pole, with two clamps for max. 62 mm dia.

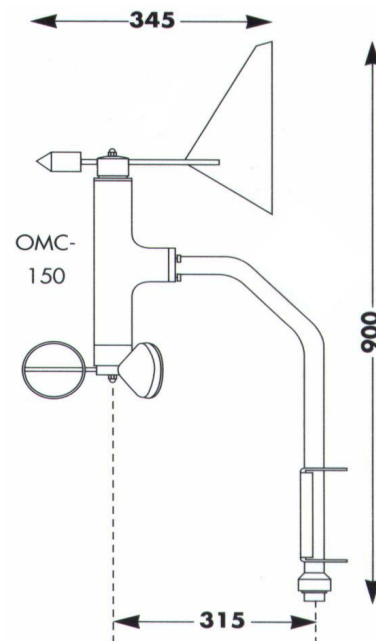

ENVIRONMENTAL

- Operating temperature -25 to 70 deg. C
- Moisture protection IP65
- Humidity 5 to 90%
- EMC EN 50081-1 class B, EN 50082-2

ACCESSORIES

- OMC-156 EEx Junction Box
- OMC-154 Calibration Certificate

ACCURACY

- Speed 2% FRO
- Speed range 0,3..75 m/s
- Direction ± 2 degrees
- Direction range 0..360 degrees (no gap)